

# R-100

## UNIVERSAL STEERING WHEEL CONTROL INTERFACE

The Interface **CARAV R-100** represents the compact box with the wires deduced outside which are connected to wires Quadlock the regular head device of the car. The signal is deduced on the new head device through infra-red port or socket mini-jack. Interface works with all vehicles, which have resistive steering wheel control.

**CARAV R-100** supports all car audio head units with remote control / or compatible with remote control. Programming occurs from remote control of the head-unit. Interface allows to make the programming for each button of wheel ONE or TWO functions (short or long pressing).

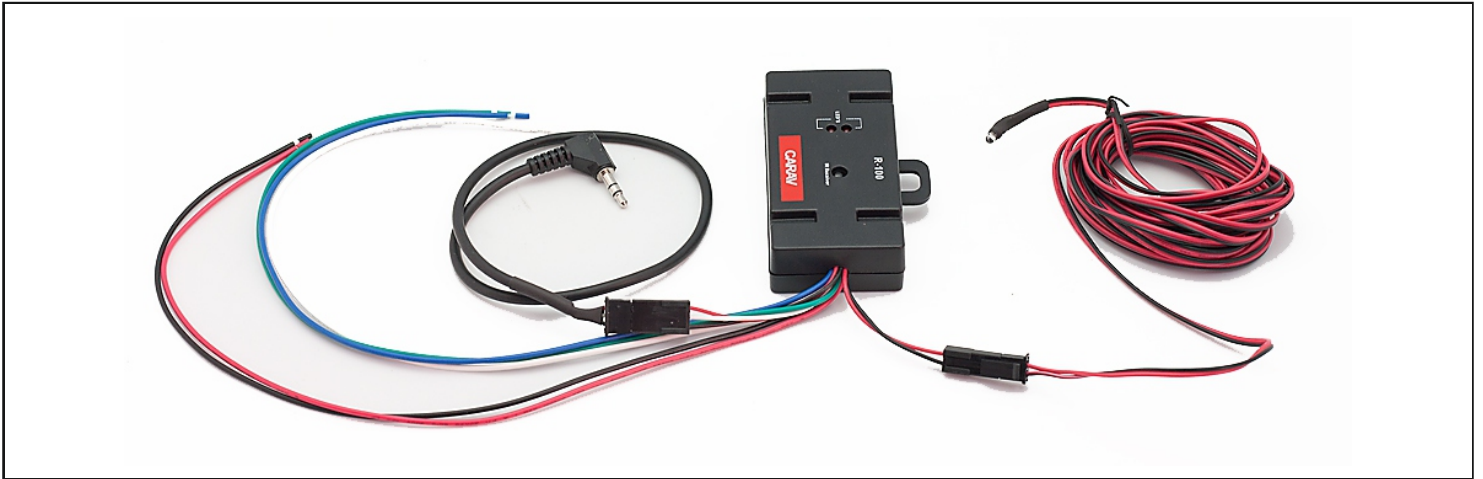

### Steering Wheel Control Interface

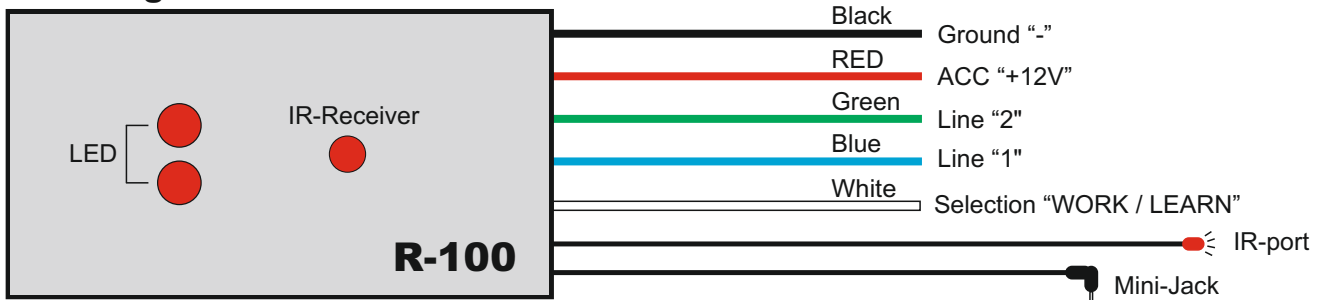

#### How to connect Interface:

1. Connect Red wire with ACC +12V
2. Connect Black, Green and Blue (if necessarily) wires to wires on regular Quadlock of the car according to electrical scheme (please see some pictures for some vehicles on other pages of this manual).
3. If the head-unit has no socket mini-jack for steering wheel control - establish IR-port on the roof of car salon in direct visibility of the head-unit. In this case, need to isolate Mini-Jack socket!
4. If head-unit has Mini-Jack socket for steering wheel control, then you need to cut IR-port and isolate the wire!

# R-100

## UNIVERSAL STEERING WHEEL CONTROL INTERFACE

### How to learn Interface:

It is possible to appoint to each button one or two commands. For example for button SEEK + (on a wheel) it is possible to appoint command SEEK+ for short pressing and PRESET+ for long pressing. For button MUTE it is possible to appoint command POWER (for long pressing) etc ...

Important: please check White wire. It must be not connected with GROUND !

1. Connect ACC +12V, thus one of LED will quickly blink.
2. Connect White wire with ground (Interface enter at the learning mode).
3. Press and keep button SEEK + until one LED will light up red.
4. Direct remote control at interface, press and keep (1-2 sec) button SEEK +. The LED should shut down (command confirmed), otherwise repeat point 4 at first. The button on a wheel has learned one command - SEEK+.
5. To appoint to the same button on a wheel the second command, press it and keep until two red LEDs will light up.
6. Direct remote control at interface, press and keep (1-2 sec) button PRESET +. Two LEDs should shut down (command confirmed), otherwise repeat point 5 at first. The button on a wheel has learned the second command - PRESET+. If you need SEEK+ you must short press, if you need PRESET+ - long press.
7. For Learning of other buttons on a wheel - execute similarly points 3,4 (5,6 - if necessary) for other commands.
8. Disconnect a white wire from GROUND and isolate! The device is ready to work!

### How to restart Interface:

1. Remove ACC +12V from Interface.
2. Connect White wire with the GROUND.
3. Connect ACC +12V to the Interface, two LEDs will blink red. Interface has restarted and ready for a new learning procedure.

# R-100

## UNIVERSAL STEERING WHEEL CONTROL INTERFACE



ALFA ROMEO

**WARNING!** All connectors are shown from Terminal-side, NOT from Wire-side!

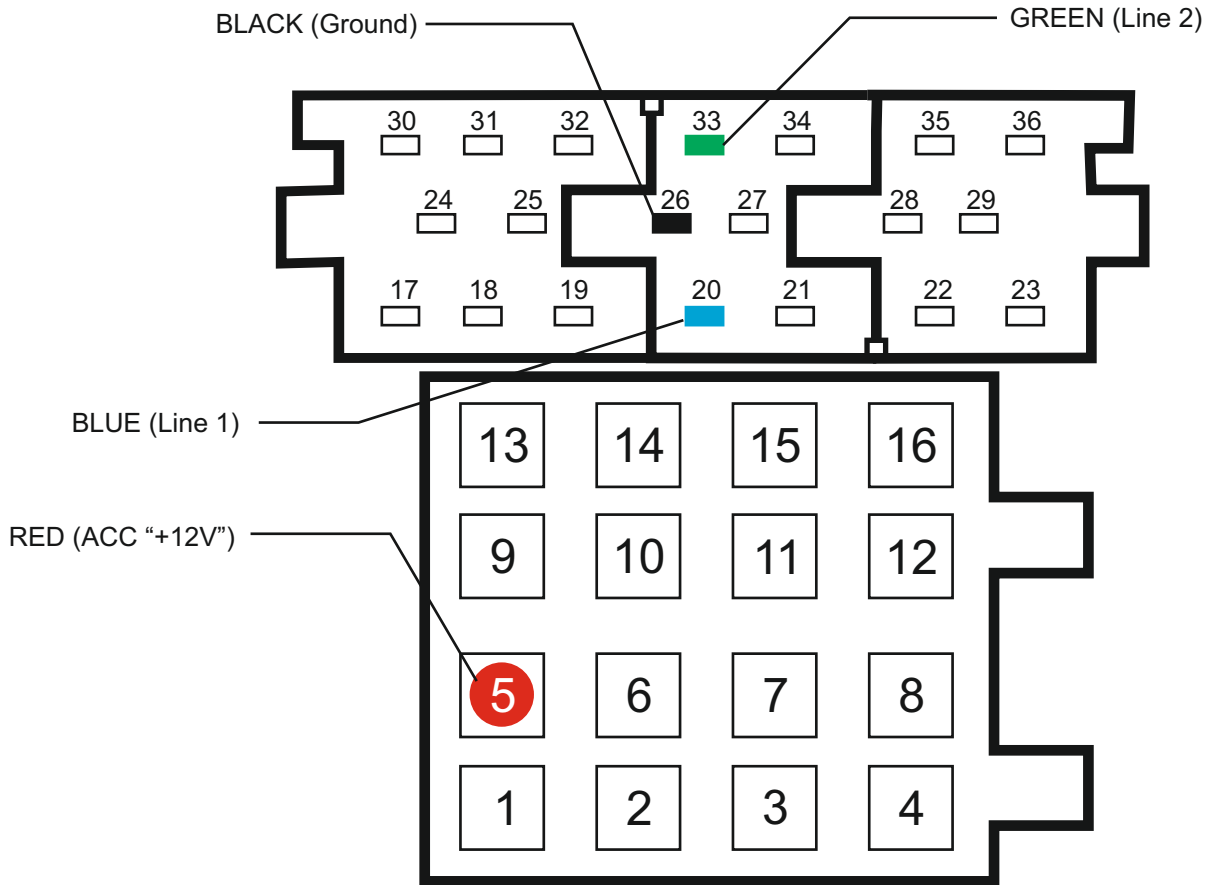

# R-100

## UNIVERSAL STEERING WHEEL CONTROL INTERFACE



BMW

**WARNING!** All connectors are shown from Terminal-side, NOT from Wire-side!

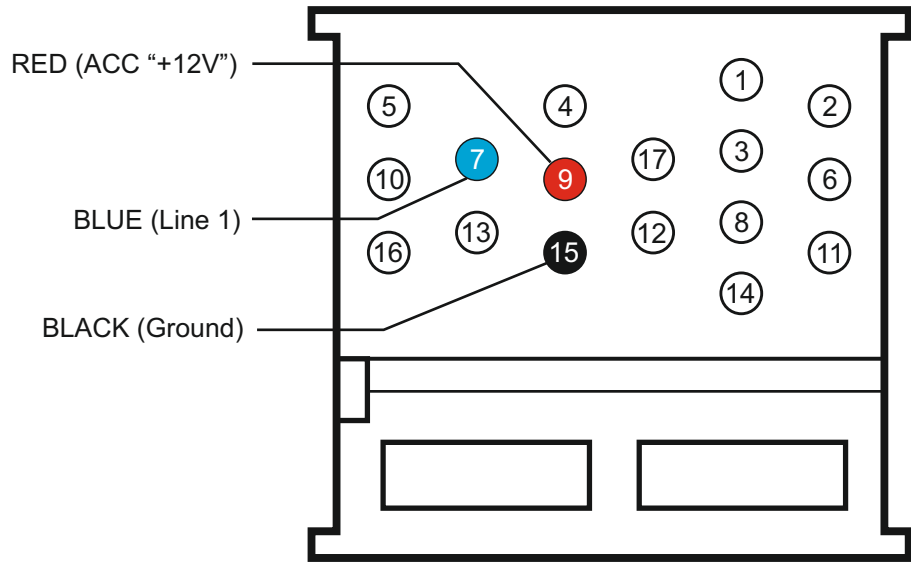

17-Way Round Pin i-BUS Vehicles

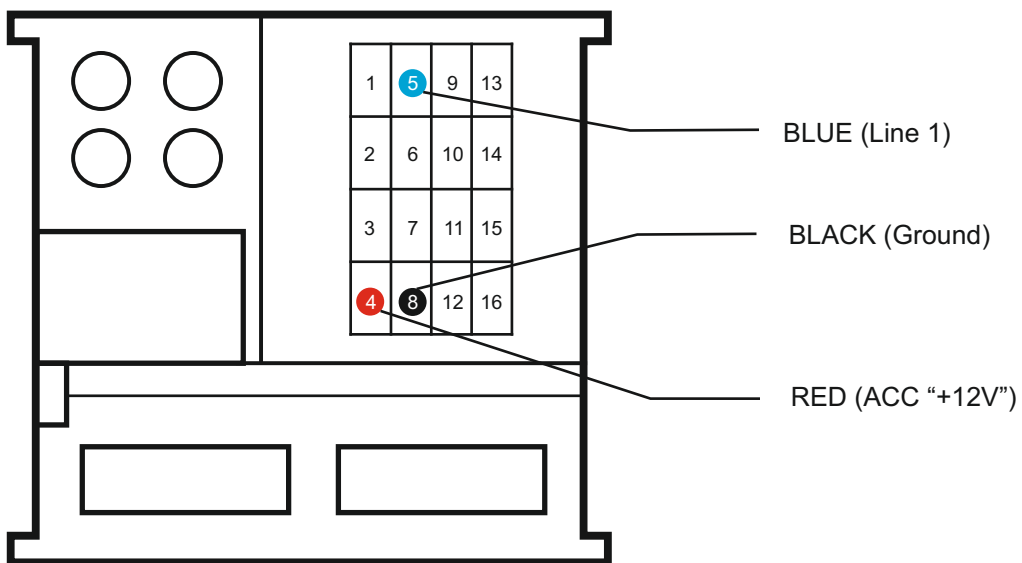

Quadlock (Fakra) i-BUS Vehicles

# R-100

## UNIVERSAL STEERING WHEEL CONTROL INTERFACE



CHEVROLET

**WARNING!** All connectors are shown from Terminal-side, NOT from Wire-side!

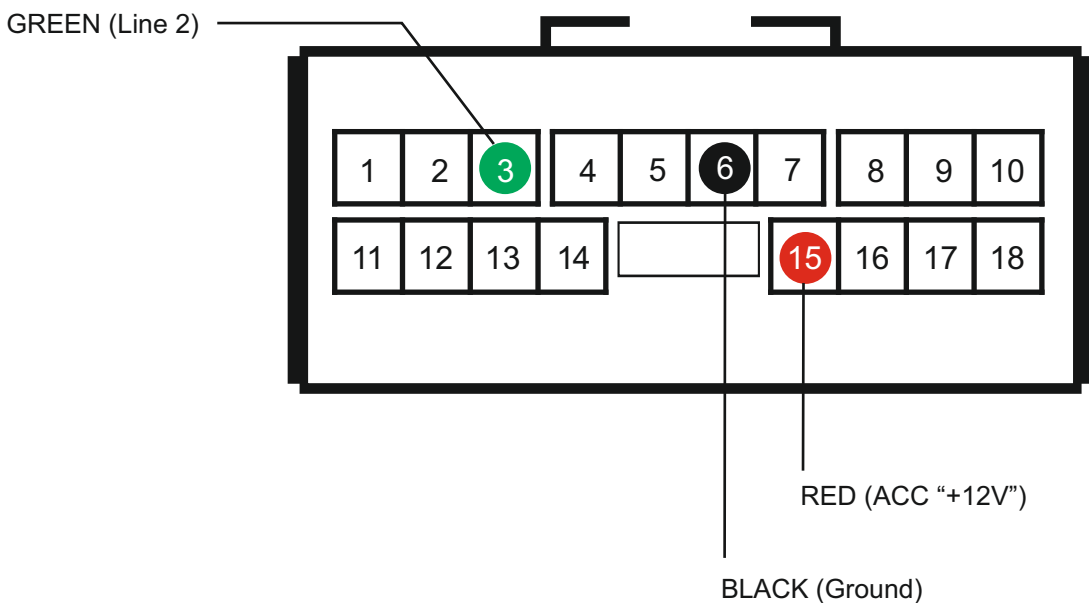
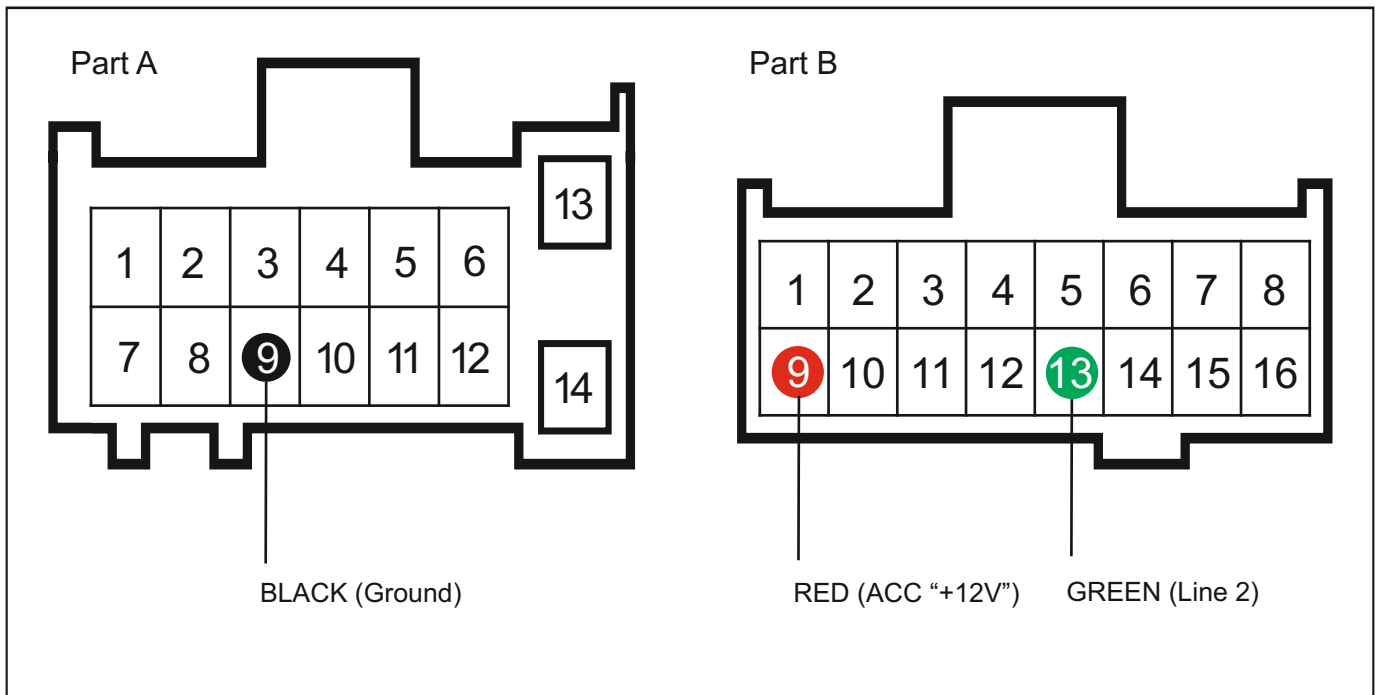

# R-100

## UNIVERSAL STEERING WHEEL CONTROL INTERFACE



CITROËN

**WARNING!** All connectors are shown from Terminal-side, NOT from Wire-side!

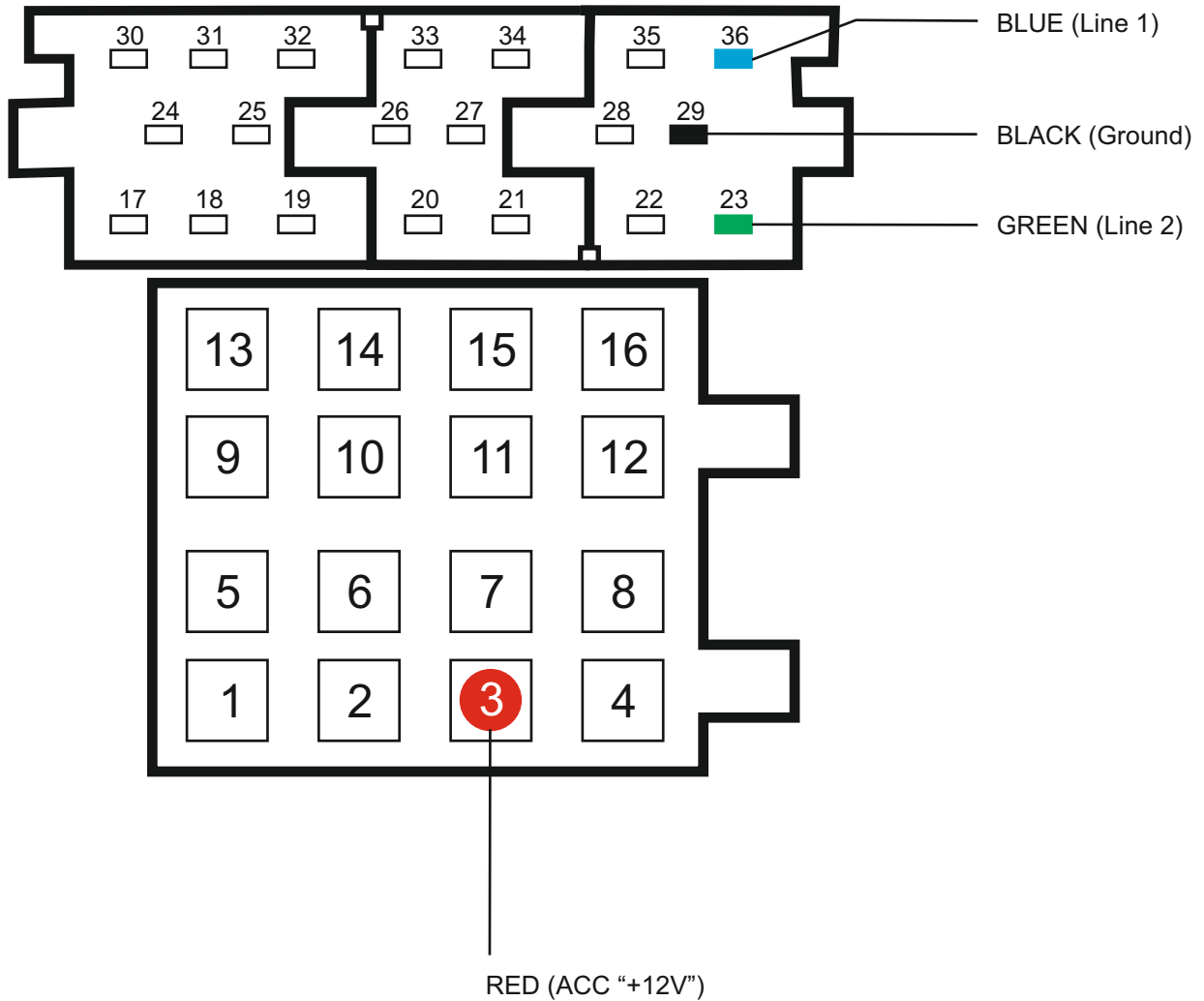

# R-100

## UNIVERSAL STEERING WHEEL CONTROL INTERFACE



FIAT

**WARNING!** All connectors are shown from Terminal-side, NOT from Wire-side!

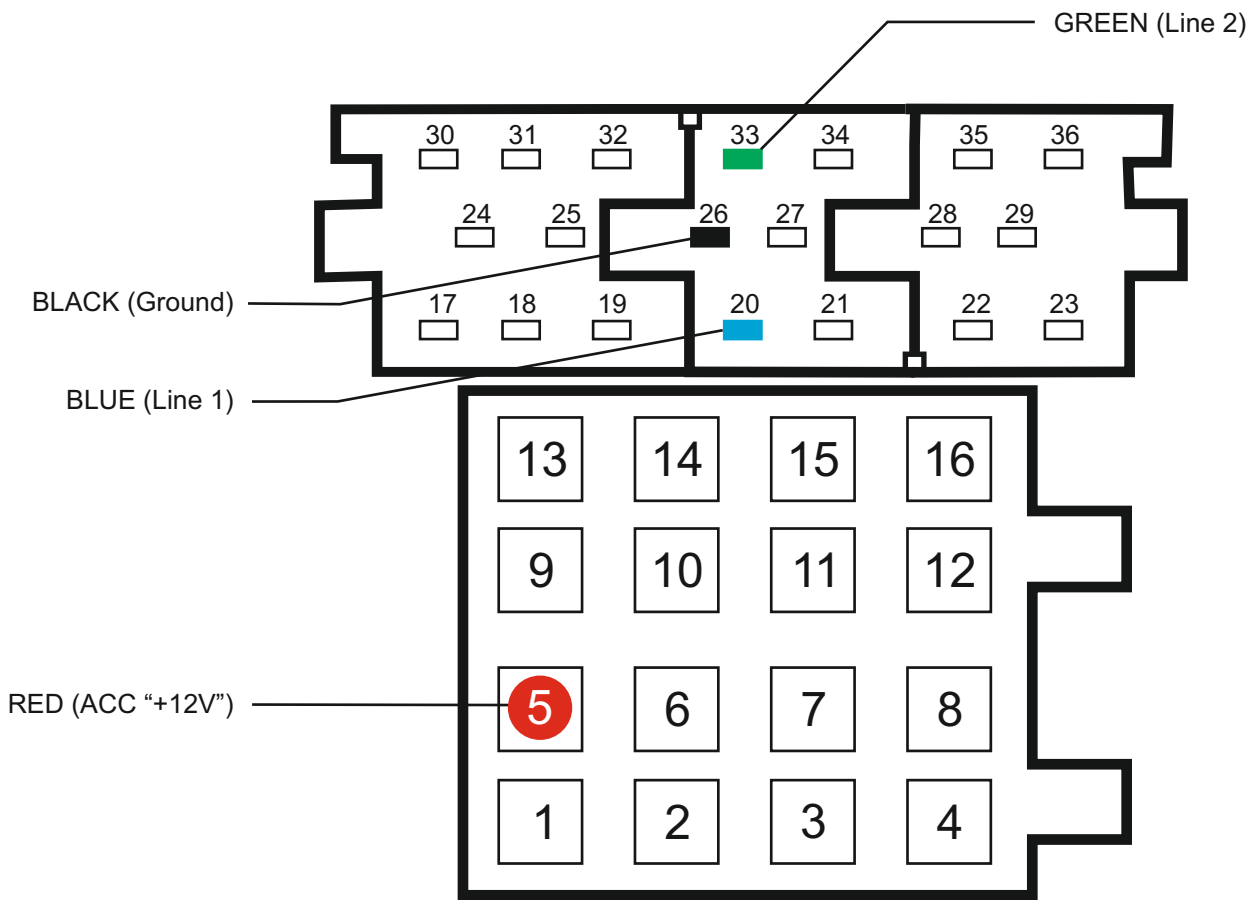

# R-100

## UNIVERSAL STEERING WHEEL CONTROL INTERFACE



FORD

**WARNING!** All connectors are shown from Terminal-side, NOT from Wire-side!

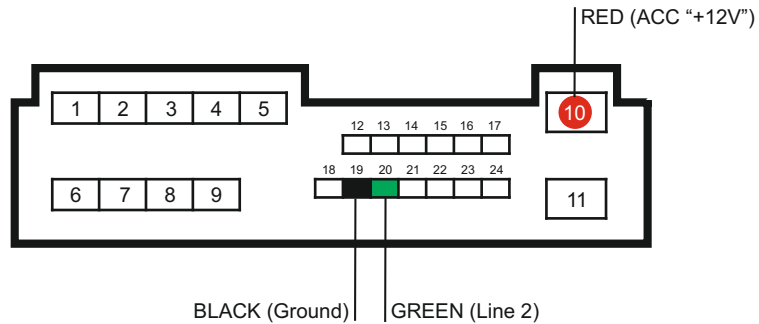
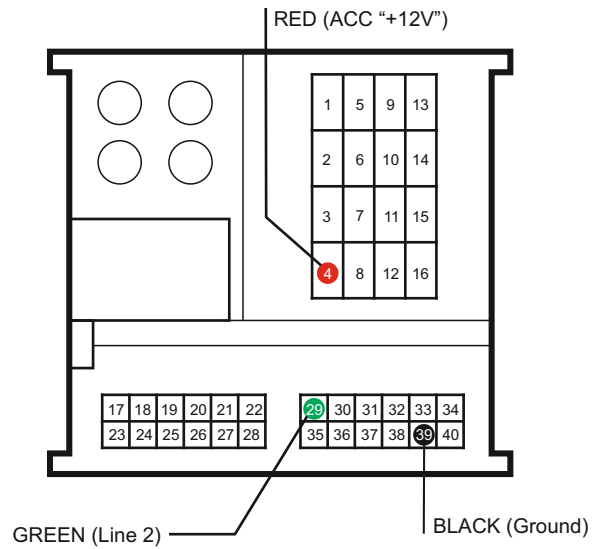
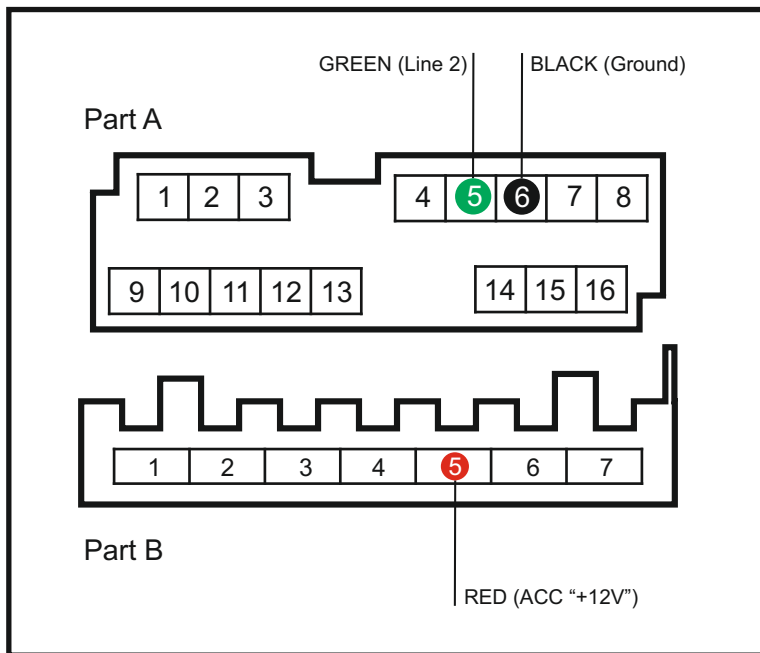



# R-100

## UNIVERSAL STEERING WHEEL CONTROL INTERFACE



**WARNING!** All connectors are shown from Terminal-side, NOT from Wire-side!

HONDA

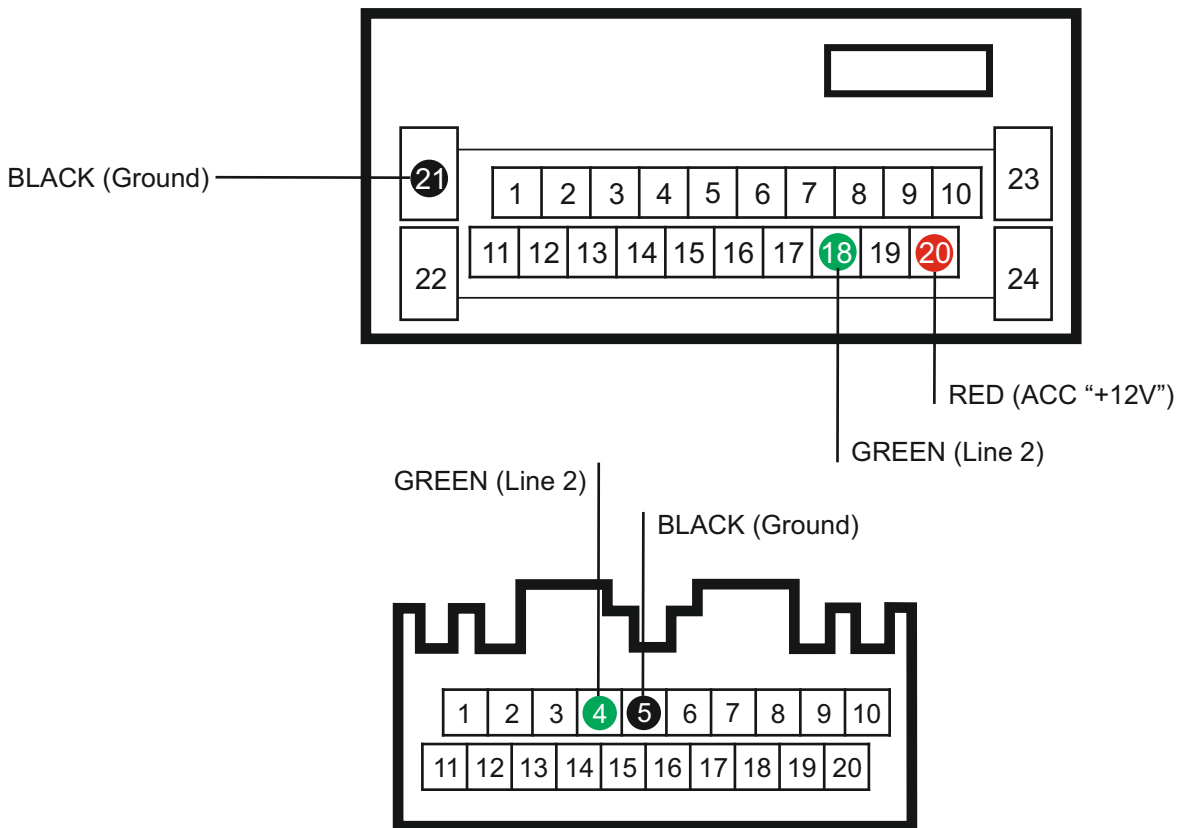
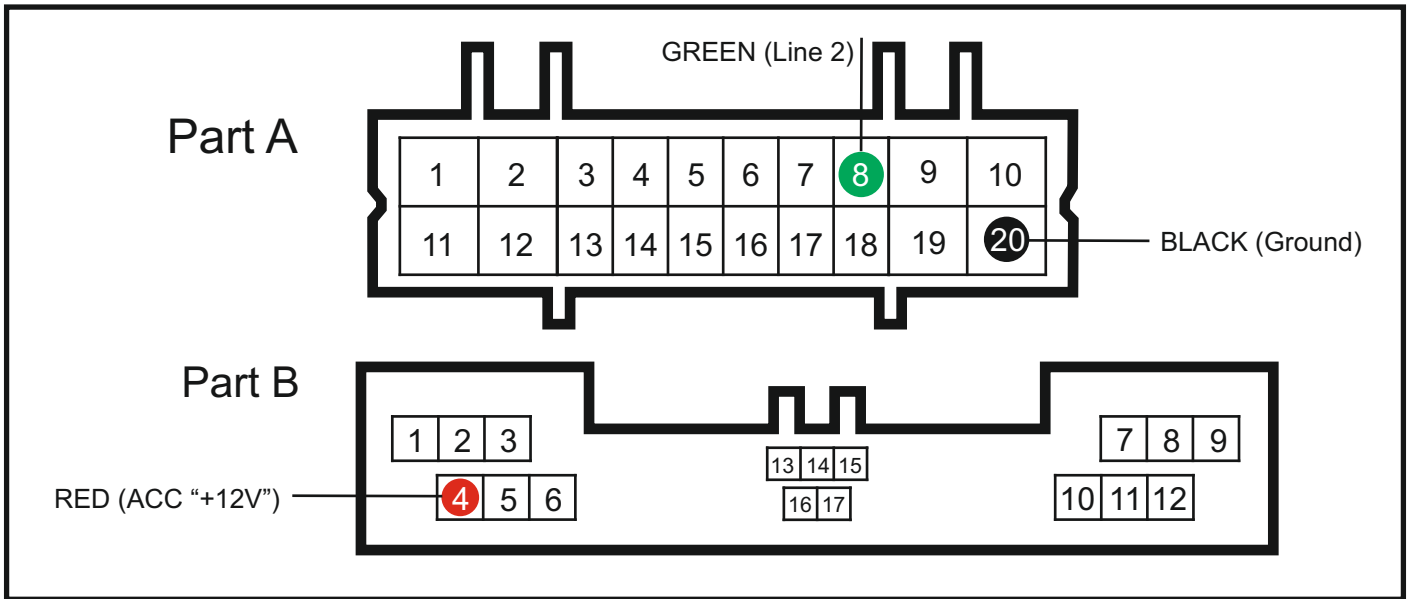

# R-100

## UNIVERSAL STEERING WHEEL CONTROL INTERFACE



HYUNDAI

**WARNING!** All connectors are shown from Terminal-side, NOT from Wire-side!

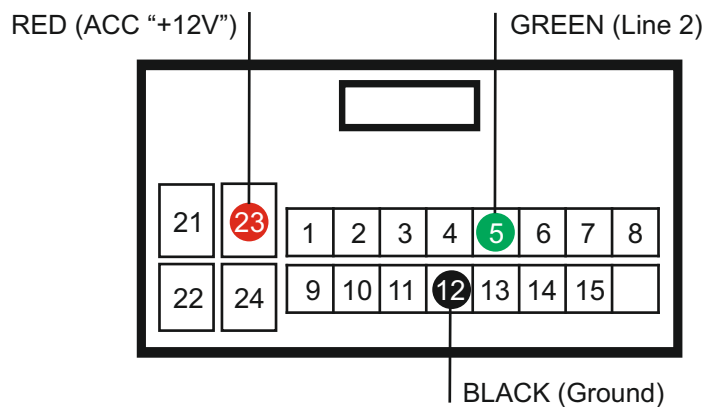
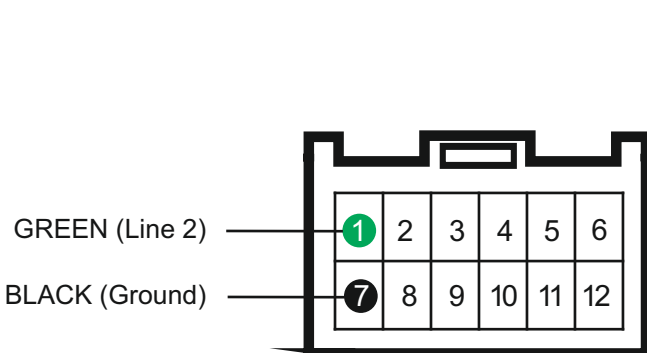
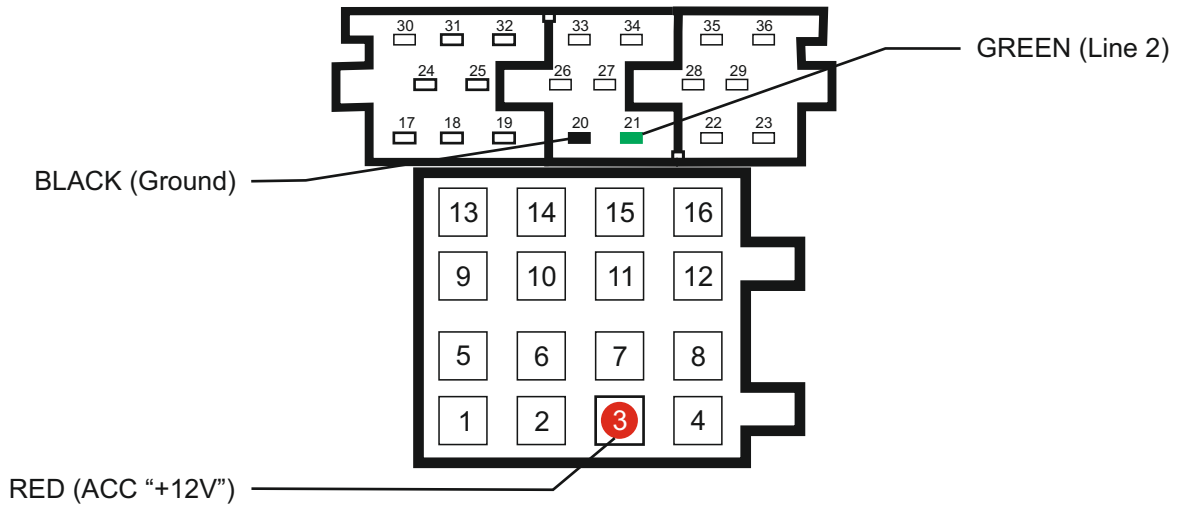
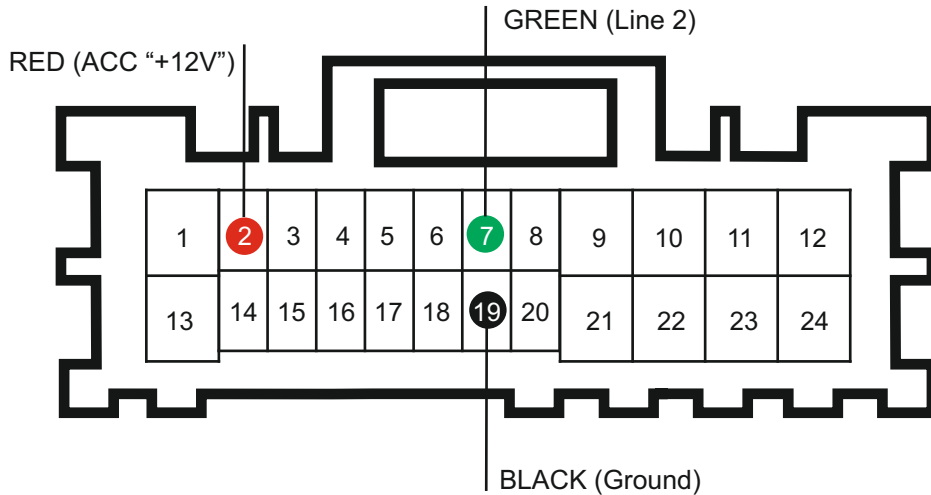

# R-100

## UNIVERSAL STEERING WHEEL CONTROL INTERFACE



INFINITI

**WARNING!** All connectors are shown from Terminal-side, NOT from Wire-side!

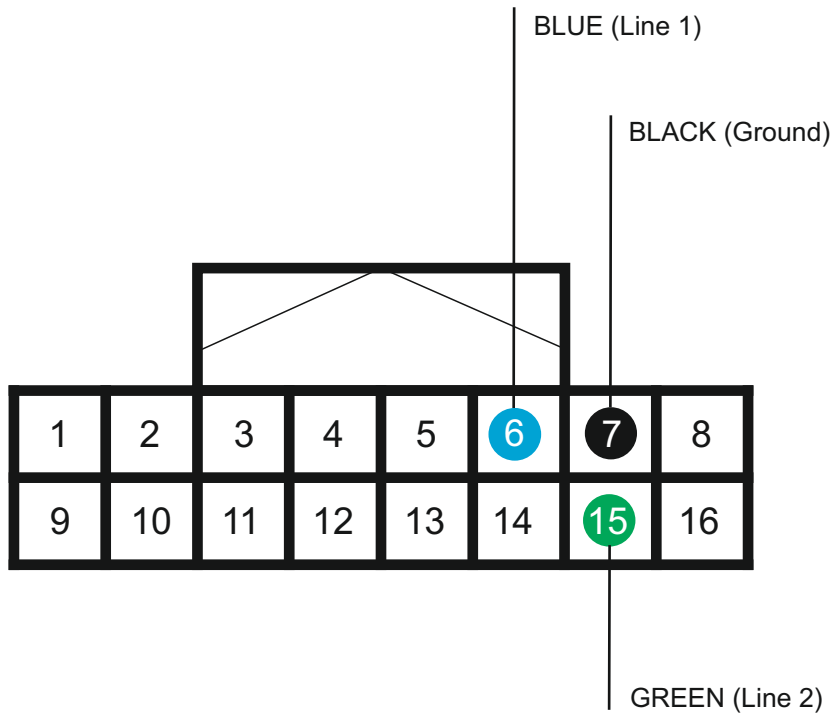

**R-100****UNIVERSAL STEERING WHEEL  
CONTROL INTERFACE**

www.carav-parts.com

**JAGUAR**

**WARNING!** All connectors are shown from Terminal-side,  
NOT from Wire-side!

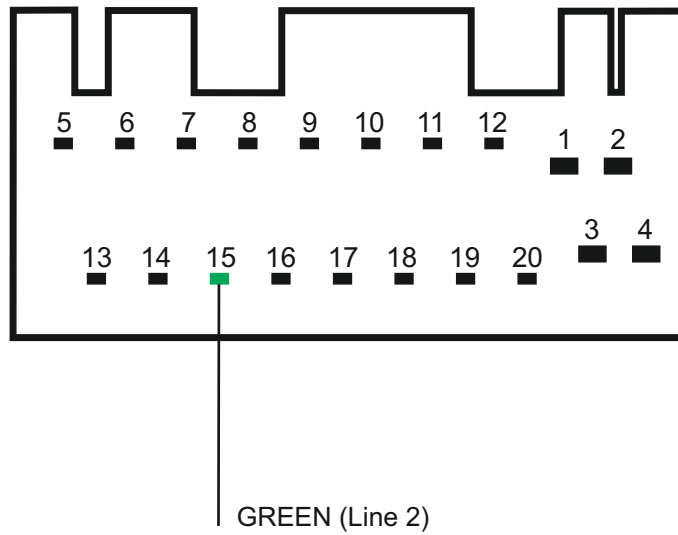

# R-100

## UNIVERSAL STEERING WHEEL CONTROL INTERFACE



KIA

**WARNING!** All connectors are shown from Terminal-side, NOT from Wire-side!

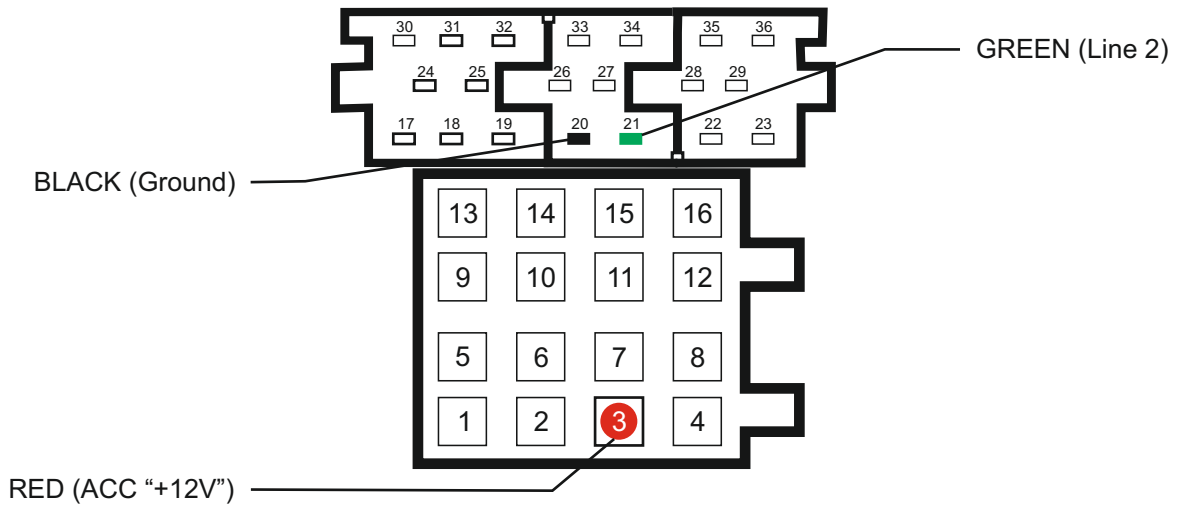
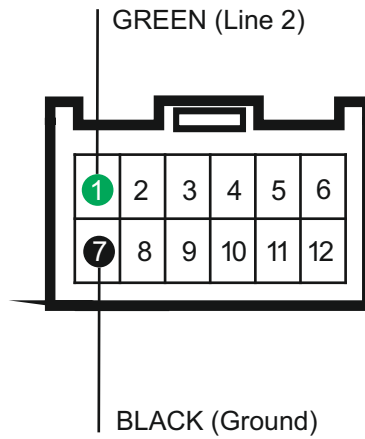
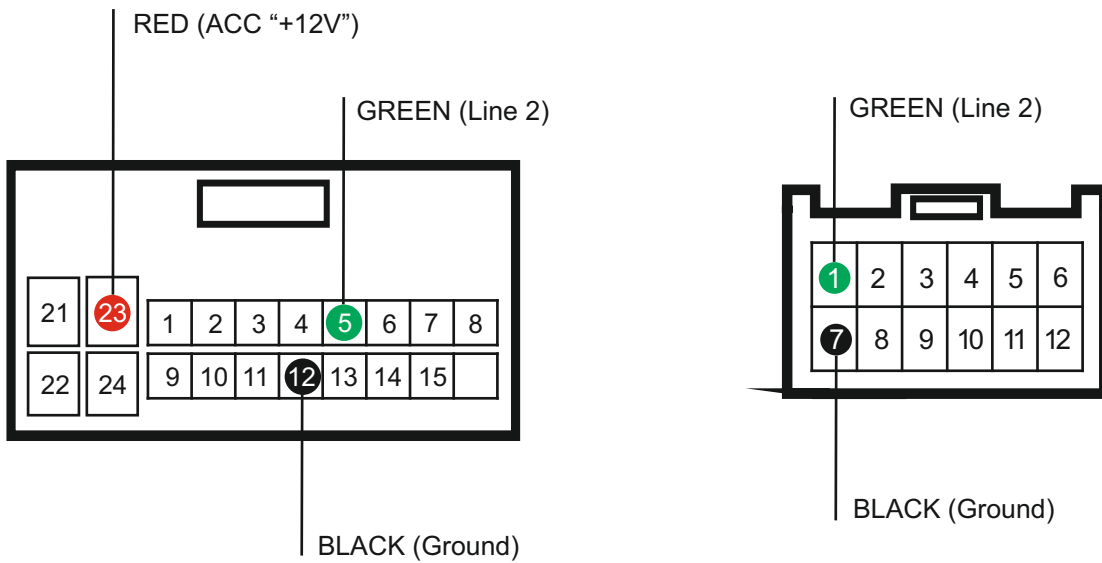

# R-100

## UNIVERSAL STEERING WHEEL CONTROL INTERFACE



LAND ROVER

**WARNING!** All connectors are shown from Terminal-side, NOT from Wire-side!

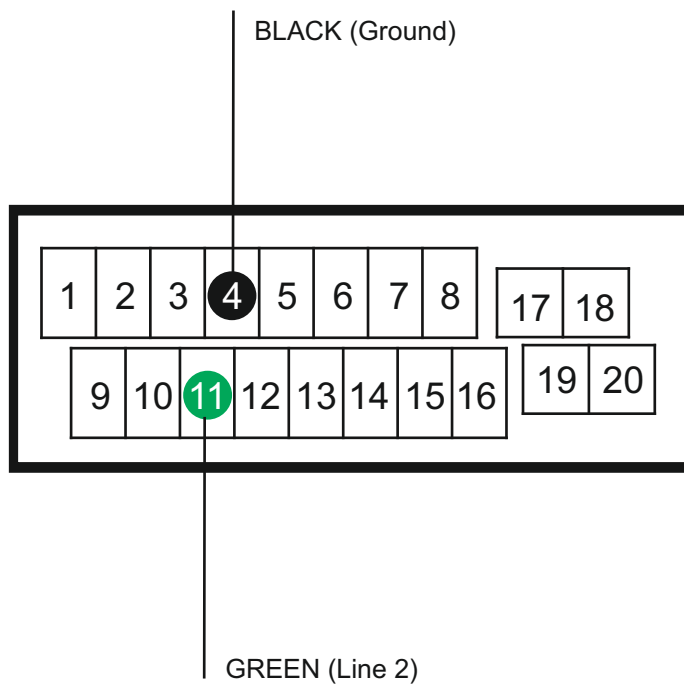

# R-100

## UNIVERSAL STEERING WHEEL CONTROL INTERFACE



LEXUS

**WARNING!** All connectors are shown from Terminal-side, NOT from Wire-side!

Part A

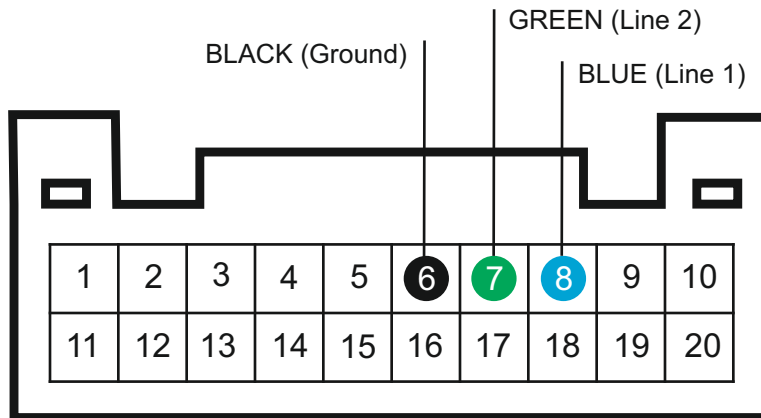

Part B

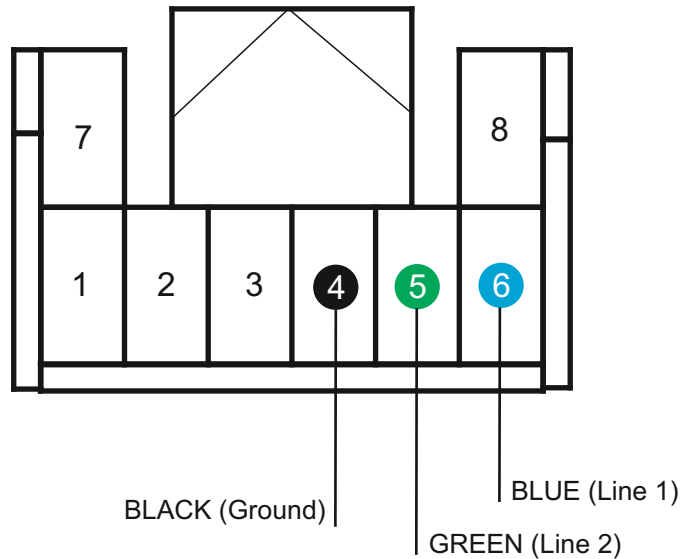
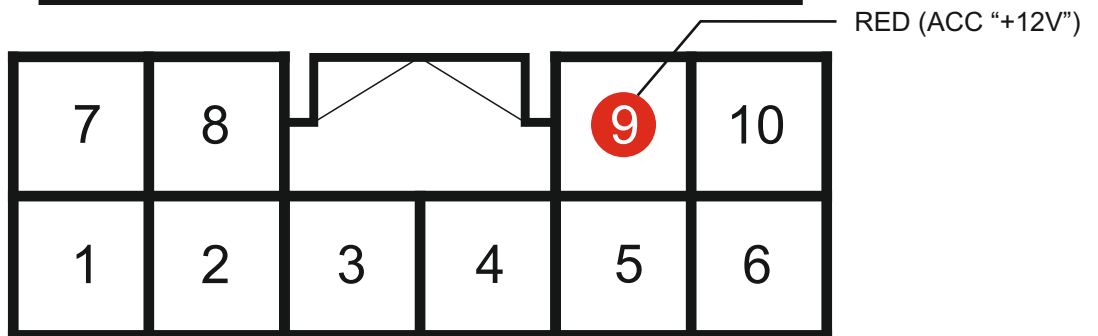

# R-100

## UNIVERSAL STEERING WHEEL CONTROL INTERFACE



MAZDA

**WARNING!** All connectors are shown from Terminal-side, NOT from Wire-side!

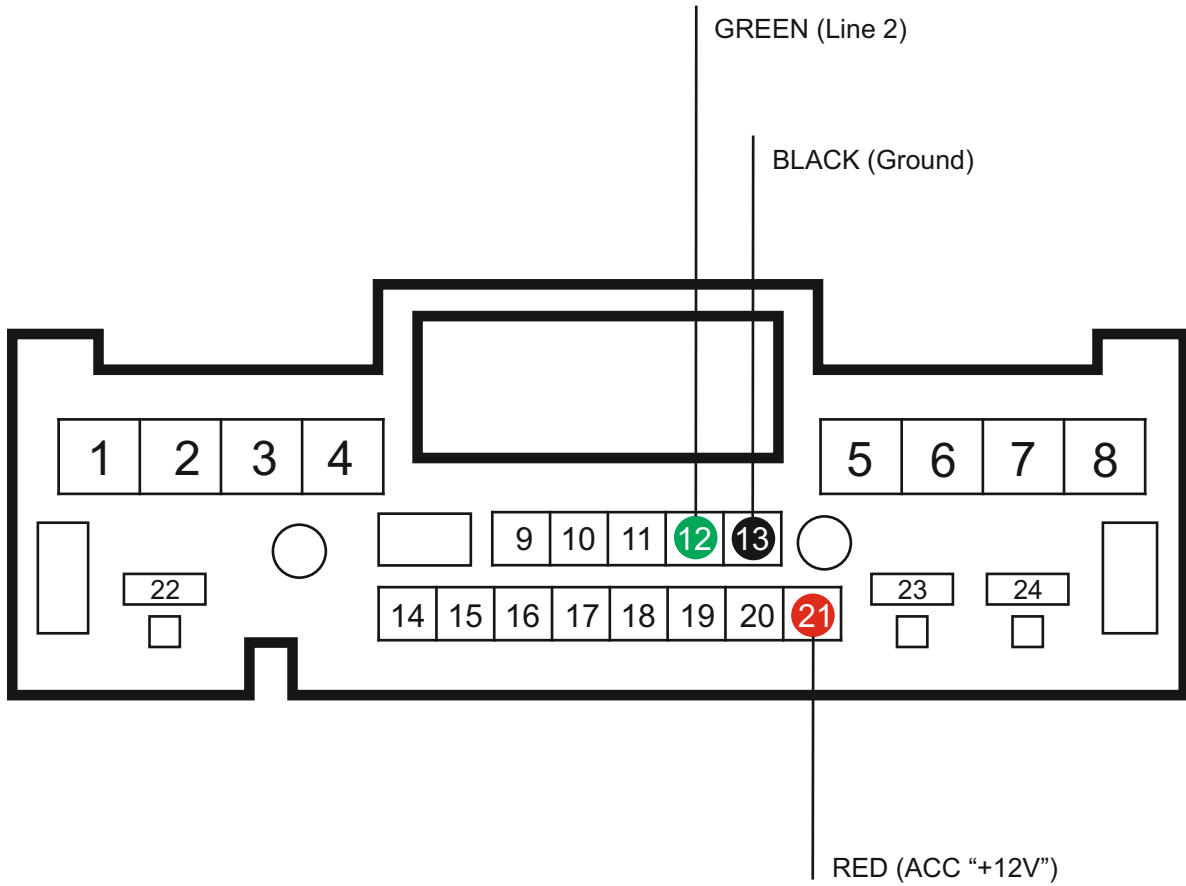



# R-100

## UNIVERSAL STEERING WHEEL CONTROL INTERFACE



MITSUBISHI

**WARNING!** All connectors are shown from Terminal-side, NOT from Wire-side!

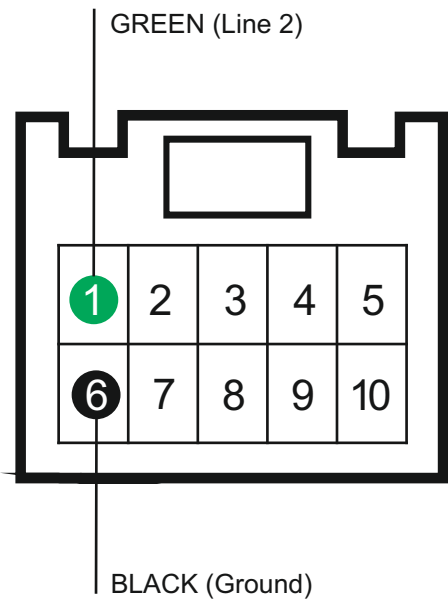
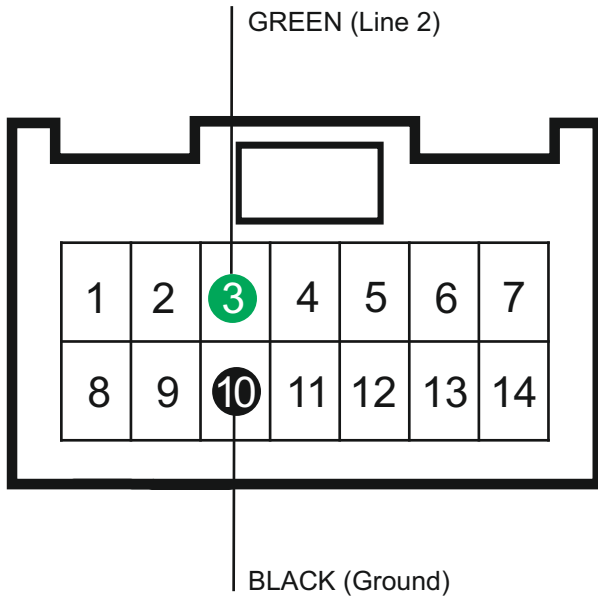
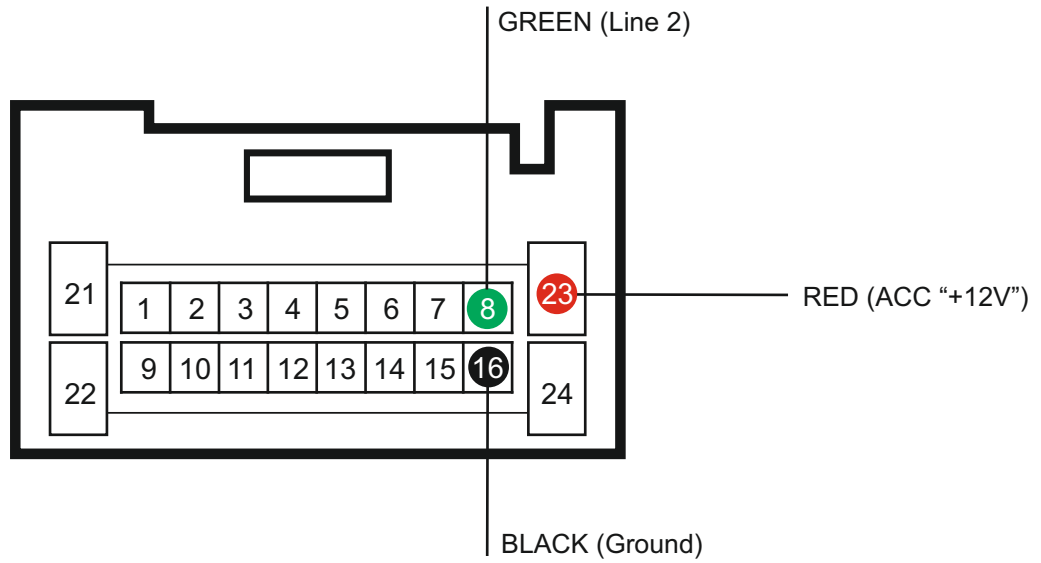

# R-100

## UNIVERSAL STEERING WHEEL CONTROL INTERFACE



NISSAN

**WARNING!** All connectors are shown from Terminal-side, NOT from Wire-side!

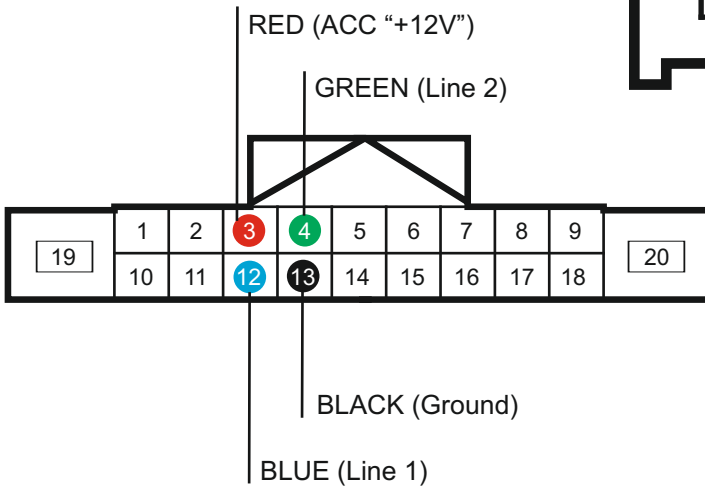
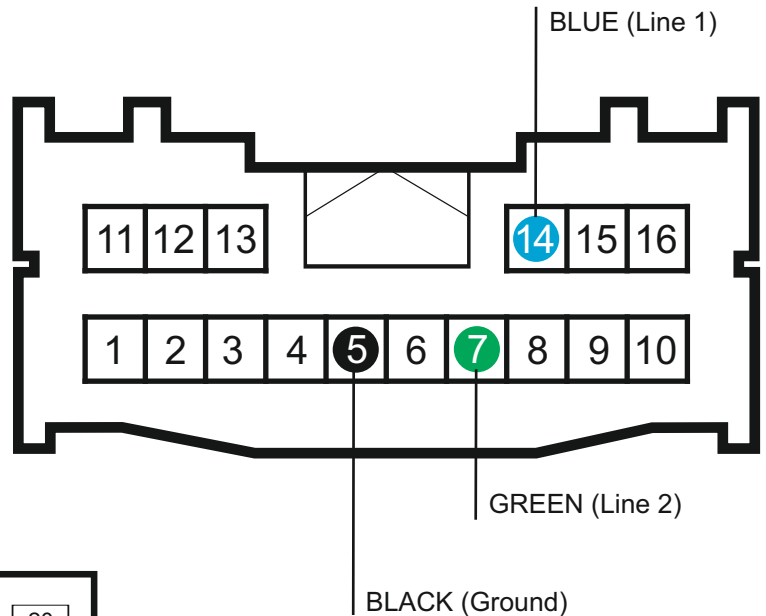
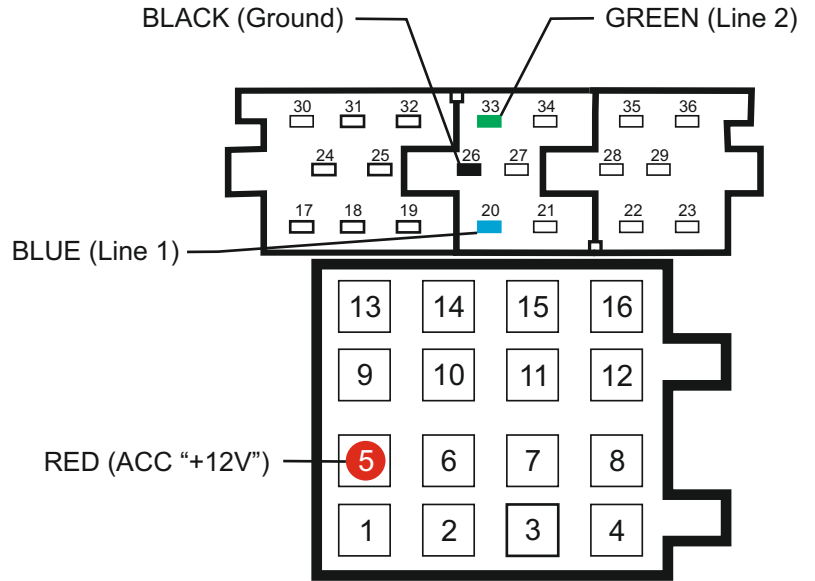
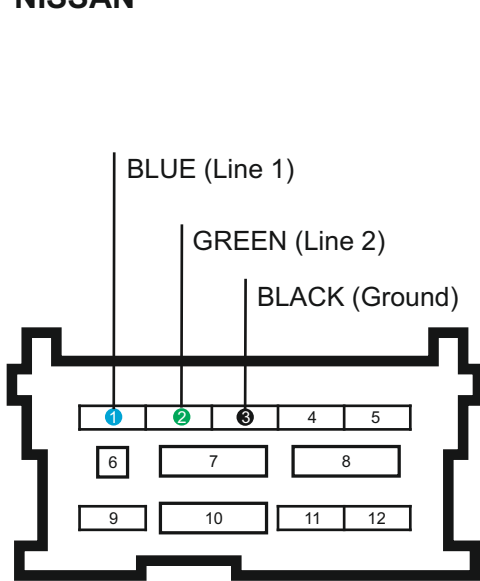

# R-100

## UNIVERSAL STEERING WHEEL CONTROL INTERFACE



OPEL

**WARNING!** All connectors are shown from Terminal-side, NOT from Wire-side!

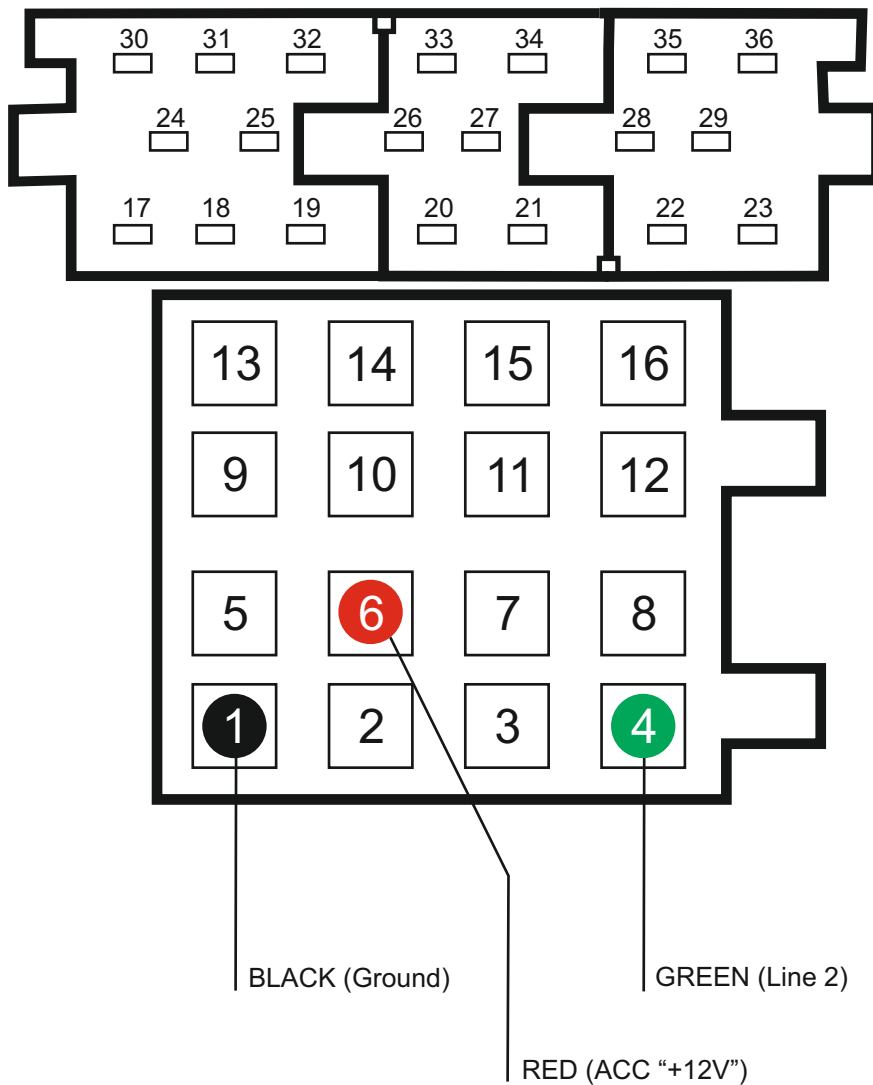

# R-100

## UNIVERSAL STEERING WHEEL CONTROL INTERFACE



PEUGEOT

**WARNING!** All connectors are shown from Terminal-side, NOT from Wire-side!

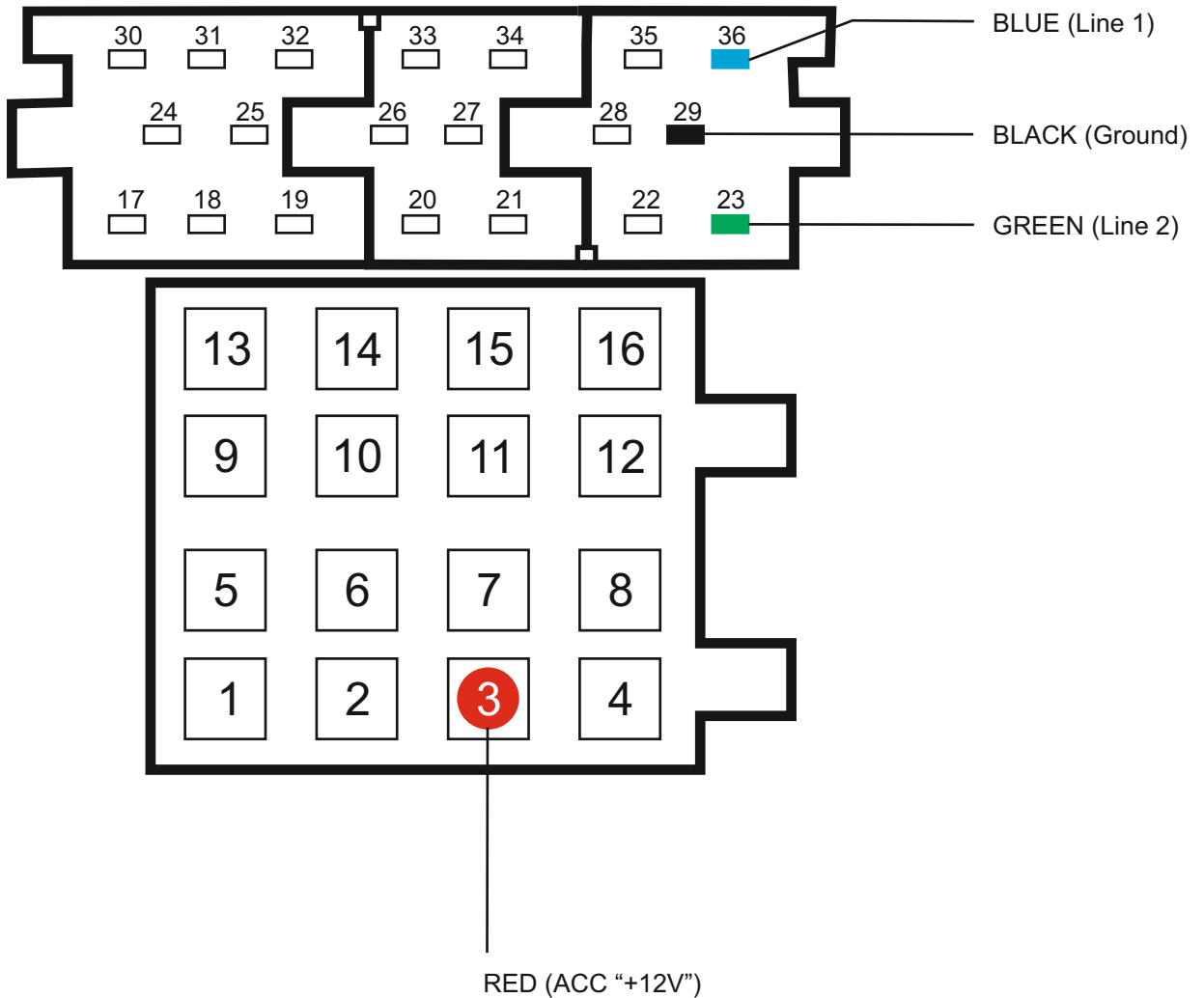

# R-100

## UNIVERSAL STEERING WHEEL CONTROL INTERFACE



ROVER

**WARNING!** All connectors are shown from Terminal-side, NOT from Wire-side!

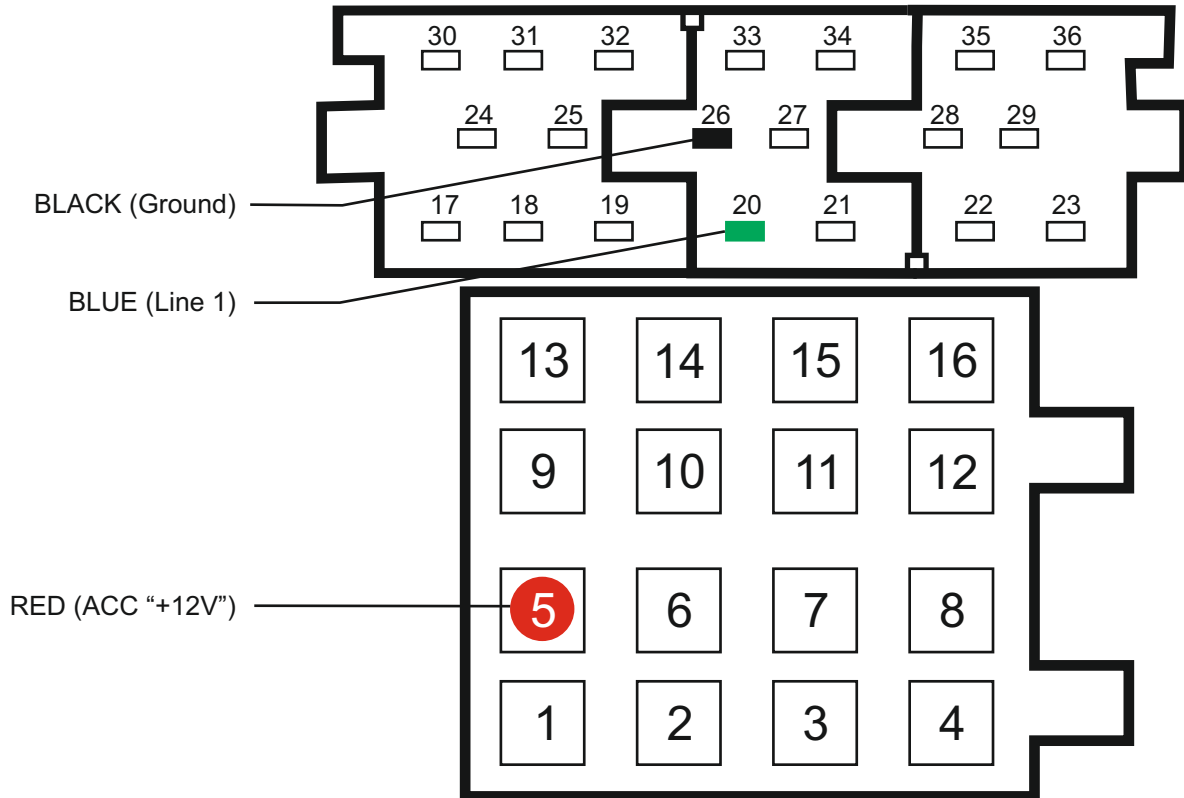

# R-100

## UNIVERSAL STEERING WHEEL CONTROL INTERFACE



SSANG YONG

**WARNING!** All connectors are shown from Terminal-side,  
NOT from Wire-side!

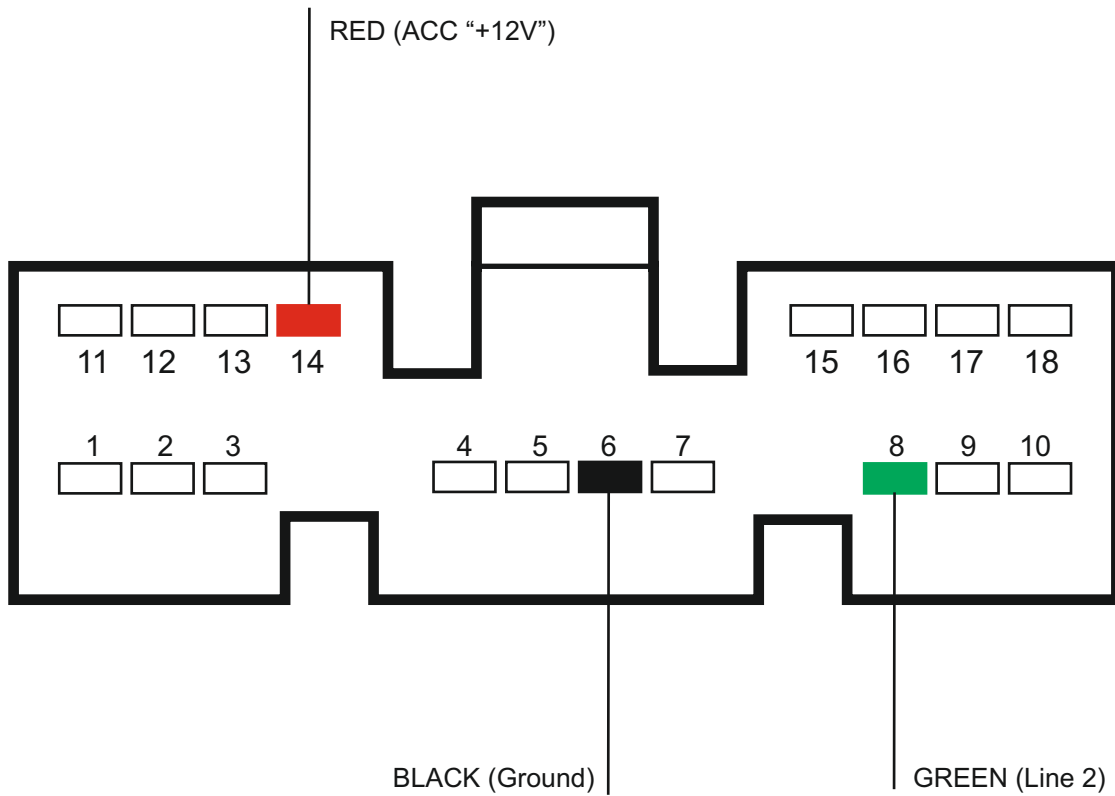

# R-100

## UNIVERSAL STEERING WHEEL CONTROL INTERFACE



SUBARU

**WARNING!** All connectors are shown from Terminal-side, NOT from Wire-side!

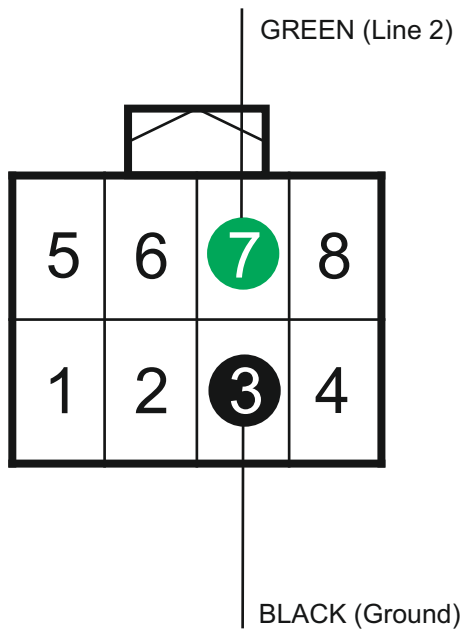
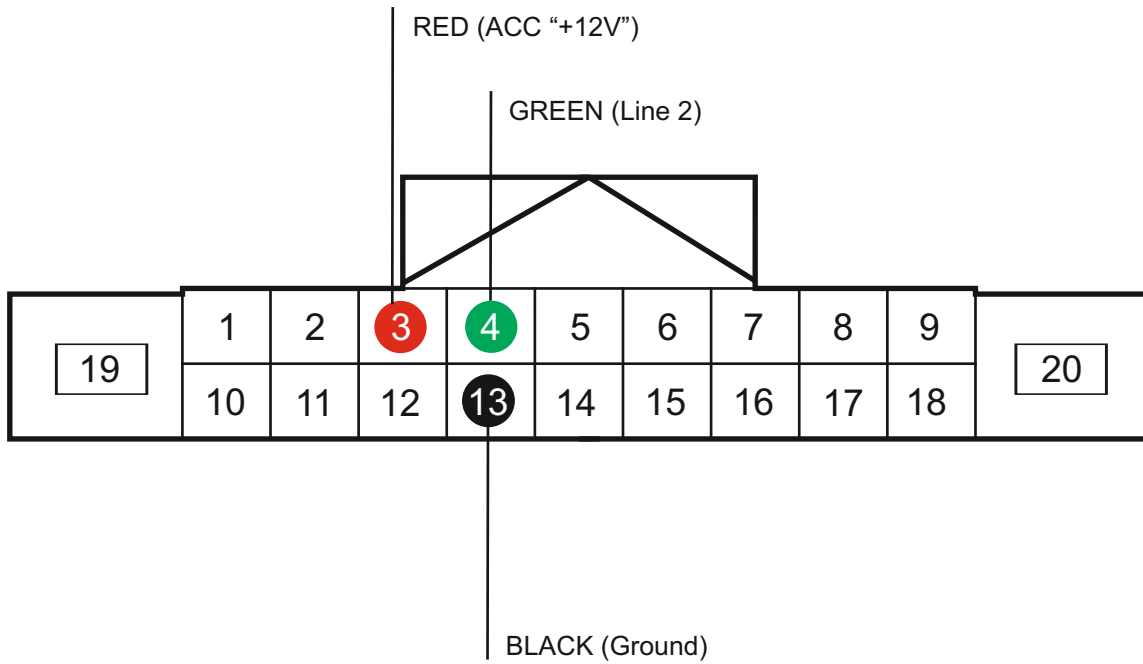

# R-100

## UNIVERSAL STEERING WHEEL CONTROL INTERFACE



SUZUKI

**WARNING!** All connectors are shown from Terminal-side, NOT from Wire-side!

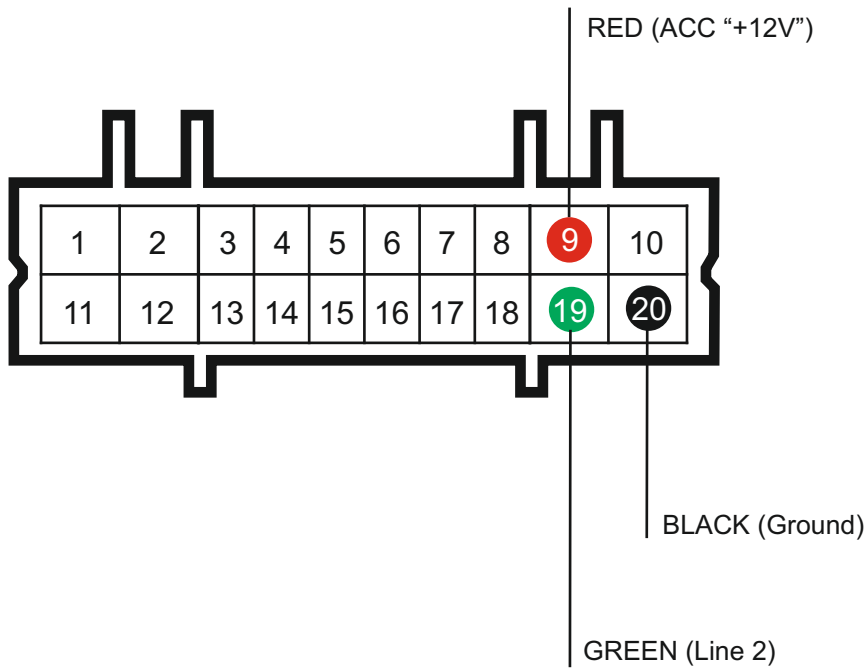



# R-100

## UNIVERSAL STEERING WHEEL CONTROL INTERFACE



TOYOTA

TOYOTA

**WARNING!** All connectors are shown from Terminal-side, NOT from Wire-side!

Part A

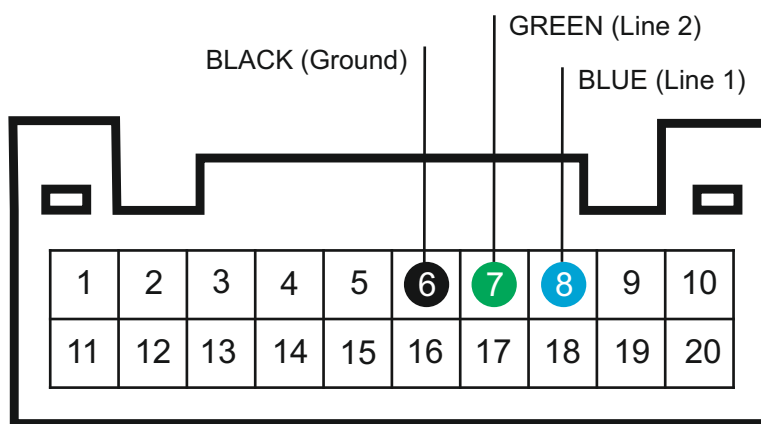

Part B

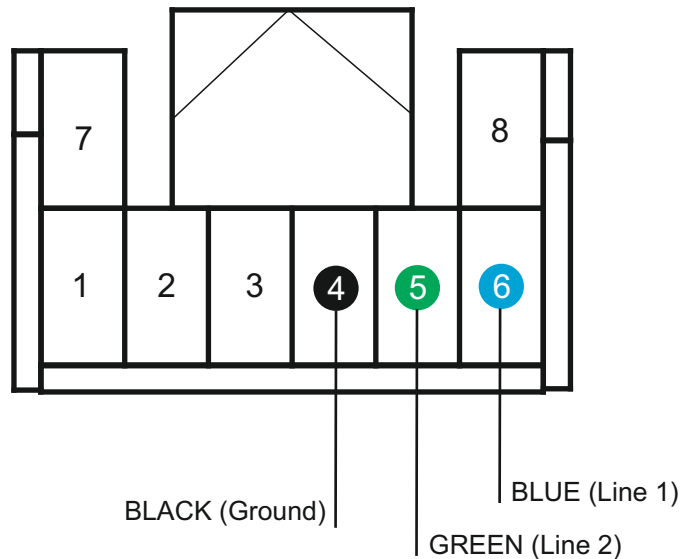
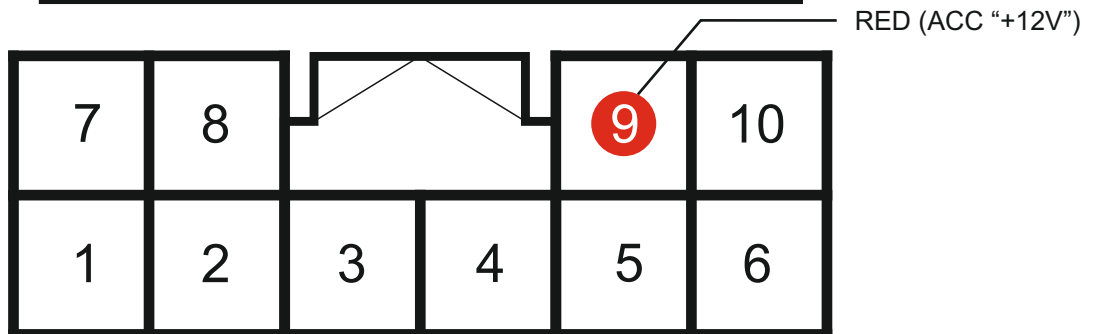

# R-100

## UNIVERSAL STEERING WHEEL CONTROL INTERFACE



VOLKSWAGEN

**WARNING!** All connectors are shown from Terminal-side, NOT from Wire-side!

